

Customer: [REDACTED]

Machine Used: TensileTurn – Industrial Upgrade Model

Date: [REDACTED]

Prepared By: [REDACTED]

Machining Conditions:

All parts were machined using Hysol MB10 coolant, with speeds and feeds selected to match the material requirements. A tailstock was used to support the components during all turning operations. The tailstock process can be observed in the video titled "[REDACTED]"

The first operation for all samples involved center drilling. This was performed after retracting the tailstock. An alternative method—center drilling closer to the chuck—was also tested to improve center alignment. The customer may choose the most suitable method based on daily production practices. A demonstration is provided in the video "[REDACTED]"

Turning Operations:

Operation 1:

Roughing and finishing of the outer diameter

- **Tool:** SDJCR, Radius: 0.4 mm

Operation 2:

Finishing of the outer diameter (right side)

- **Tool:** SDJCL, Radius: 0.4 mm

Operation 3:

M12 thread cutting on both left and right sides

- **Tool:** Outer diameter threading tool

Notes:

- Aside from the non-round cross-sectional shape, no major difficulties were encountered during machining.
- The Non-Standard ASTM 0.505" specimen had a long and narrow geometry, making it prone to vibration and chatter, particularly during the finishing stage. To mitigate this, the surface speed was significantly reduced, resulting in a duller (opaque) finish, though dimensional accuracy remained within acceptable limits.
- All specimens were machined under standard testing conditions. Customers performing continuous machining may benefit from optimizing feeds, speeds, and tool selection to improve efficiency and surface quality.



Notes:

- The original specified part length had to be reduced due to the supplied blanks being shorter than required for the complete part and proper fixturing.
- The first sample was damaged due to slippage in the chuck. To prevent recurrence, a custom back stopper was manufactured to secure the samples during machining.
- Several “horizontal” samples could not be machined, as their irregular geometry prevented proper clamping using both 3-jaw and 4-jaw self-centering chucks. Off-centered clamping caused vibration and tool failure. → For such irregular samples, it is strongly recommended to use an independent 4-jaw chuck, or to pre-machine the part into a shape suitable for secure clamping.
- All machining was performed using standard cutting parameters consistent with general testing procedures. Customers may optimize feed rates, cutting speeds, and tooling for improved cycle times and surface finishes during full-scale production.
- Machining was performed in alignment with the requirements outlined in ASTM E8.

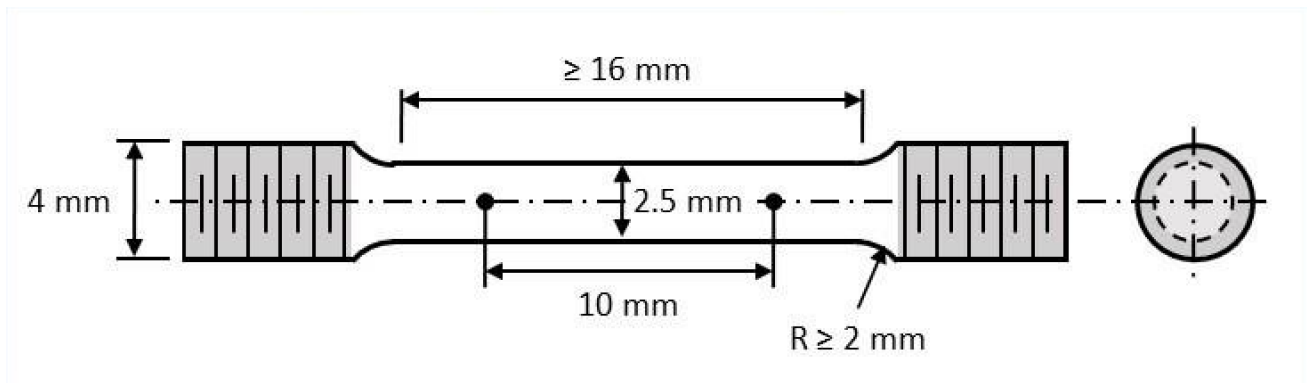

ASTM E8 Schematic Representation

Cutting Conditions & Video Documentation:

Non-Treated 718 Parts:

- **Surface Speed (SFM):** 45 meters/minute
- **Feed per Revolution:** 0.15 mm/rev
- **Depth of Cut:** 0.5 mm per radial pass
- **Cycle Time:** 3 minutes
- **Videos:**



**718 Heat Treated Parts:**

- **Surface Speed (SFM):** 22 meters/minute
- **Feed per Revolution:** 0.15 mm/rev
- **Depth of Cut:** 0.25 mm per radial pass
- **Cycle Time:** 6 minutes
- **Videos:**
 - [REDACTED]
 - [REDACTED]

**W722 Heat Treated – Piece 1:**

- **Surface Speed (SFM):** 22 meters/minute
- **Feed per Revolution:** 0.15 mm/rev
- **Depth of Cut:** 0.25 mm per radial pass
- **Cycle Time:** 6 minutes
- **Video:** [REDACTED]



**W722 Heat Treated – Piece 2:**

- **Surface Speed (SFM):** 22 meters/minute
- **Feed per Revolution:** 0.15 mm/rev
- **Depth of Cut:** 0.25 mm per radial pass
- **Cycle Time:** 6 minutes
- **Video:** [REDACTED]

